

5231

thermostatic mixing valve
for multiple outlets



altecnic

5231 thermostatic mixing valve for multiple outlets



Application

Thermostatic mixing valves are used to maintain the domestic hot water supplied to the user at a constant and safe temperature, when variations in the hot and cold water supply conditions and draw off flow rates occur.

The 5231 range has been designed especially for centralised systems which demand high flow rates, for example with multiple outlets such as shower and wash basins.

Operating Principle

The controlling element of the mixing valve is a temperature sensor fully immersed in the mixed water outlet port, which expands or contracts, continually maintaining the correct proportion of hot and cold water entering the valve.

Even when the supply pressures drop, due to draw off of hot and cold water by other users on the same system, or variations in the incoming water temperatures, the mixing valve automatically responds and maintains the mixed outlet water at the required temperature.

Construction Details

Component	Material	Grade
Body	DZR	BS EN 1982 CB752S
Shutter	Polymer	PPS G40
Springs	Stainless steel	
Seals	EPDM	
Cap	Polymer	ABS

Product Code	Size	Connection	Type
523170	1¼"	screwed iron	M x M x M without check valve
523180	1½"	screwed iron	M x M x M without check valve
523190	2"	screwed iron	M x M x M without check valve

Dimensions

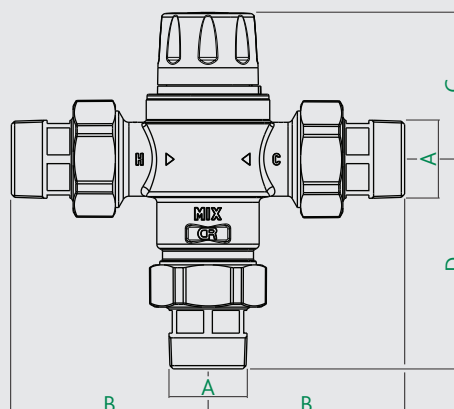

Prod Code	A	B	C	D	kg
523170	R1¼	104.5	109	86.5	3.38
523180	R1½	121	129	90.5	3.81
523190	R2	131	139	95.5	5.58

Technical Data

Max. working pressure:	14 bar - Static 5 bar - Dynamic
Max. inlet temperature:	90°C
Max. inlet pressure ratio (H/C or C/H):	2:1
Accuracy:	±2°C
Setting Range:	35 to 65°C
Male threads:	BS EN 10226

Flow Chart and Kv Values

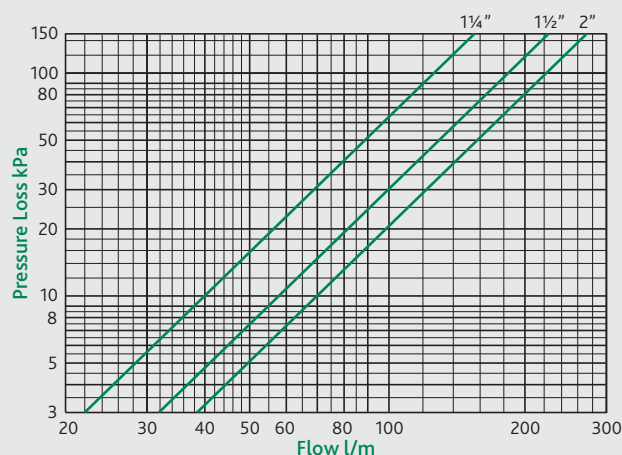

Flow rates recommended to ensure stable operation and accuracy of ±2°C (balanced pressure Hot/Cold)

Size	Kv - m³/h	*ΔP = 1.5 bar	Min. - m³/h	Max.* - m³/h
1¼"	7.6	1¼"	1.0	9.3
1½"	11.0	1½"	1.5	13.5
2"	13.3	2"	2.0	16.3

E & O.E

Altecnic Ltd Mustang Drive, Stafford, Staffordshire ST16 1GW

T: +44 (0)1785 218200 E: sales@altecnic.co.uk

Registered in England No: 2095101

altecnic.co.uk

AL 143 03-08-13

altecnic